

FOXY, BLACK/ORANGE/GREY, 2021

obj. č: 010.21073



Specyfikacje techniczne

produkowane rozmiary

S 380mm / M 420mm / L 470mm / XL 510mm

waga

15,5 Kg

rama

Foxy 29 6061 Alloy Stealth Evo, hydroformed tubing, Zero Suspension System, 150mm travel, Forward Geometry, one piece Monoblock upper link, Boost 12x148mm rear axle, 73mm BSA bottom bracket, dedicated 1x drivetrain design, telescopic seatpost internal routing, MAX capacity sealed bearings, ISCG 05

widelec

Fox 36 29 Float FIT GRIP EVOL Rhythm, 160mm, tapered steerer tube, Boost 15x110mm axle, offset 44mm. Settings: sweep adjust compression, low-speed rebound, air preload

stery

Onoff Saturn tapered for 1-1/8 to 1-1/2 head tube, ACB sealed bearings, top 41x30.2x7x45x45, bottom 51.9x40x8x45x45

przerzutka

Sram SX Eagle, Type 3 roller bearing clutch, cage lock, long cage, 1x12s, X-actuation 1:1

manetki

Sram Trigger SX Eagle, 12s, X-Actuation 1:1

klamki hamulca

Sram G2 R, tool-free reach adjust

uchwyty

Sram SX Eagle, Boost, DUB axle, Direct Mount chain ring, S/M size: 170mm, L/XL size: 175mm

support

Sram DUB BSA, sealed bearings, 73mm

kierownica

Onoff Sulfur 1.0 double butted 6061 alloy, rise: 20mm, width: 780mm, 9 backsweep, 5° upsweep, 31.8mm barbore Onoff Twin, 1lock-on, 135mm

mostek

Onoff Sulfur FG 30mm 0, 6061 forged alloy, 31.8mm barbore

sztyca

Onoff Pija dropper internal, diameter 31.6mm, S size: 337x100mm, M size 387x125mm, L size: 425x150mm, XL size: 465x170mm

siodełko

SDG BEL-AIR 3.0, LPU foam, steel rails

piasta przednia

Formula DC711, Boost 15x110mm, sealed bearings, IS 6 bolts

tylna piasta

Formula MST148S-4SB, Boost 12x148mm, sealed bearings, IS 6 bolts

łańcuch

Sram SX Eagle, 12s, Powerlock

kaseta

Sram PG-1210, 11-50T, 12s

szprychy
CN round stainless steel

rafki
MDK-EP1 29 TLR ASY, asymmetrical rim, 30mm
internal width, tubeless ready, 32 spokes

obudowa
Maxxis Minion DHF 29x2.5 WT, tubeless ready, 3C MAXX TERRA compound,
EXO+ protection, 120TPI, folding bead

zamówienie numer
010.21073

amortyzator
Fox Float DPS LV EVOL Performance, 205x62.5mm. Settings: rebound, 3-
position compression adjustment (Open/Mid/Lock), air preload. Trunnion top
mount, 22.2x10mm bottom bushings

przedni hamulec
Sram G2 R, 4-piston caliper, Centerline 200mm IS
6 bolts one-piece rotor, steel-backed organic pads

tylny hamulec
Sram G2 R, 4-piston caliper, Centerline 180mm IS 6 bolts one-piece rotor, steel-
backed organic pads

tylna obudowa
Maxxis Aggressor 29x2.3, tubeless ready, dual
compound, Exo protection, 60TPI, folding bead

regulacja amortyzatora
Light compression, extralight rebound, air volume spacer 0.6

korba
32T, steel, X-Sync 2

mocowanie przerzutki
Mondraker M068

Geometria

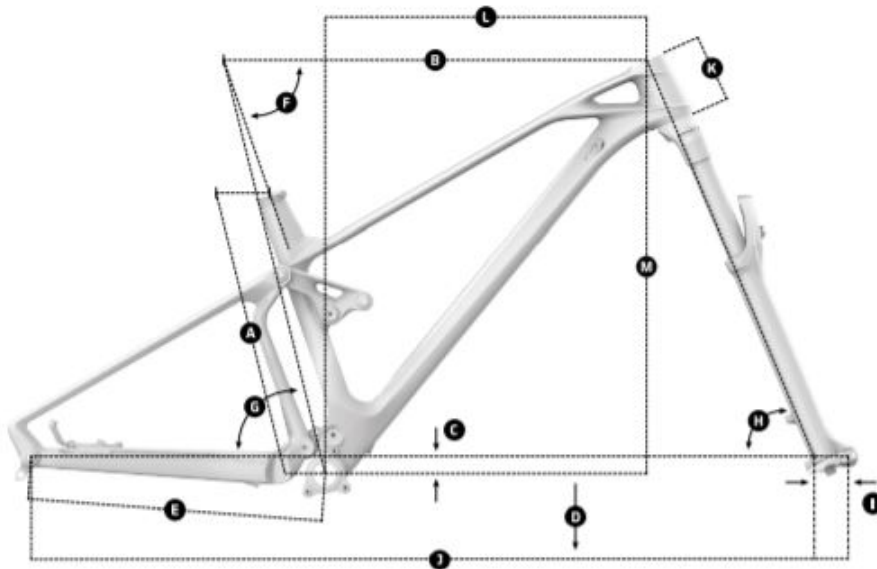

GEOMETRY

Size	S	M	L	XL
A Seat Tube Length	380 mm	420 mm	470 mm	510 mm
B Top Tube Length	606 mm	629 mm	654 mm	678 mm
C Bottom Bracket Drop	-21 mm	-21 mm	-21 mm	-21 mm
D Bottom Bracket Height	352 mm	352 mm	352 mm	352 mm
E Chainstay Legth	435 mm	435 mm	435 mm	435 mm
F Seat Tube Angle, Actual	70.5°	70.5°	70.5°	70.5°
G Seat Tube Angle, Effective	75.5°	75.5°	75.5°	75.5°
H Head Tube Angle	66°	66°	66°	66°
I Fork Offset	44 mm	44 mm	44 mm	44 mm
J Wheelbase	1187 mm	1210 mm	1236 mm	1262 mm
K Head Tube Length	90 mm	100 mm	115 mm	130 mm
L Reach	450 mm	470 mm	490 mm	510 mm
M Stack	605 mm	614 mm	628 mm	642 mm