

DUSK R, BLACK/GREEN/YELLOW, 2021

obj. č.: 010.21296



Specyfikacje techniczne

produkowane rozmiary

S 380mm / M 420mm / L 450mm / XL 490mm

waga

23,6 Kg

rama

Dusk 6061 Alloy Stealth Evo, e-Bike Optimized Zero Suspension System, 150mm travel, Forward Geometry, integrated internal non-removable battery, Boost 12x148mm rear axle, tapered head tube, one-piece Monoblock upper link, HHG internal cable routing, MAX capacity sealed bearings, oversize 17mm axles, integrated dropout speed sensor.*Optional external battery

widelec

Fox 36 29 Float FIT GRIP EVOL Rhythm, 160mm, e-bike tuned, tapered steerer tube, Boost 15x110mm axle, 44mm offset. Settings: sweep adjust compression, low-speed rebound, air preload

stery

Onoff Saturn tapered for 1-1/8 to 1-1/2 head tube, ACB sealed bearings, top 41x30.2x7x45x45, bottom 51.9x40x8x45x45

przerzutka

Shimano Deore M6100, SGS, Shadow+, 12s

manetki

Shimano Deore M6100, Rapid Fire Plus, 12s

klamki hamulca

Shimano M4100, servo wave, alloy lever, tooled reach adjust

uchwyty

Shimano STEPS EM600, 165mm

kierownica

Onoff Sulfur 1.0 double butted 6061 alloy, rise: 20mm, width: 780mm, 9 backsweep, 5 upsweep, 31.8mm barbore Onoff Twin, 1lock-on, 135mm

mostek

Onoff Sulfur FG 30mm 0, 6061 forged alloy, 31.8mm barbore

szttyca

Onoff Pija dropper internal, diameter 31.6mm, S size: 387x125mm, M size: 425x150mm, L/XL size: 465x170mm

siodełko

Mondraker e-MTB custom design

piasta przednia

Formula DC711, Boost 15x110mm, sealed bearings, IS 6 bolts

tylna piasta

Formula EHL148 Boost 12x148mm, sealed bearings, IS 6 bolts

łańcuch

Shimano Deore M6100, 12s, Quick-link

kaseta

Shimano Deore M6100, 10-51T Hyperglide+, 12s

szprychy

CN round stainless steel

rafki

MDK-HP1 29, 30mm internal width, tubeless ready, 32 spokes

obudowa

Maxxis Rekon 29x2.6, tubeless ready, dual compound, EXO protection, 60TPI, folding bead

zamówienie numer

010.21296

amortyzator

Fox Float DPS LV EVOL Performance, 205x65mm. Settings: Compression 3 positions lever, low-speed rebound, air preload. Trunnion top mount, 25x10mm bottom bushings

przedni hamulec

Shimano MT420, 4 piston caliper, RT66 203mm IS 6 bolts rotor, resin pads

tylny hamulec

Shimano MT420, 4 piston caliper, RT66 203mm IS 6 bolts rotor, resin pads

tylna obudowa

Maxxis Rekon 29x2.6, tubeless ready, dual compound, EXO protection, 60TPI, folding bead

regulacja amortyzatora

Medium compression, Medium rebound, 0.4 volume spacer

korba

Shimano E8000 34T, steel, 104 BCD

mocowanie przrzutki

Mondraker M068

silnik + akumulator

Shimano STEPS EP800, computer Shimano STEPS E7000, Simplo internal 630Wh, Optional external battery: Simplo 360Wh

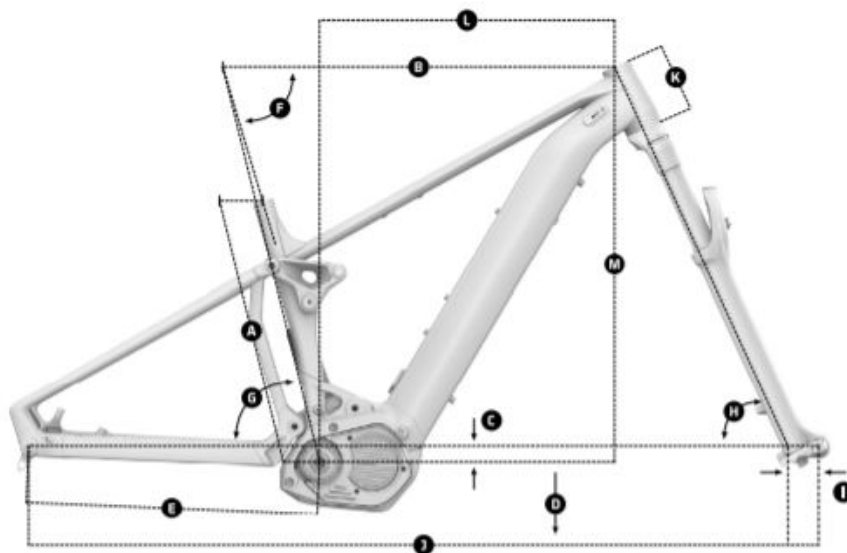
Geometria**GEOMETRY**

Size	S	M	L	XL
A Seat Tube Length	380 mm	420 mm	450 mm	490 mm
B Top Tube Length	605 mm	625 mm	650 mm	670 mm
C Bottom Bracket Drop	-25 mm	-25 mm	-25 mm	-25 mm
D Bottom Bracket Height	350 mm	350 mm	350 mm	350 mm
E Chainstay Legth	455 mm	455 mm	455 mm	455 mm
F Seat Tube Angle, Actual	73.5°	73.5°	73.5°	73.5°
G Seat Tube Angle, Effective	76°	76°	76°	76°
H Head Tube Angle	65.5°	65.5°	65.5°	65.5°
I Fork Offset	44 mm	44 mm	44 mm	44 mm
J Wheelbase	1225 mm	1245 mm	1265 mm	1285 mm
K Head Tube Length	110 mm	110 mm	130 mm	130 mm
L Reach	450 mm	470 mm	490 mm	510 mm
M Stack	622 mm	622 mm	640 mm	640 mm