

# CRAFTY R, BLACK/WHITE, 2021

obj. č: 010.21241



Sugerowana cena

**27.999,00 zł**

Aktualna cena

**24.899,00 zł**

## Specyfikacje techniczne

### produkowane rozmiary

S 380mm / M 420mm / L 450mm / XL 490mm

### waga

24,9 Kg

### rama

Crafty 6061 Alloy Stealth Evo, e-Bike Optimized Zero Suspension System, 150mm travel, Forward Geometry, internal removable battery with integrated alloy cover, Boost 12x148mm rear axle, tapered head tube, one-piece Monoblock upper link, HHG internal cable routing, MAX capacity sealed bearings, oversize 17mm axles, integrated dropout speed sensor, exclusive plastic motor covers.

### widelec

Fox 38 29 Float FIT GRIP EVOL Performance, 160mm, e-bike tuned, tapered steerer tube, Boost 15x110mm axle, 44mm offset. Settings: 3 positions with micro adjust compression, low-speed rebound, air preload

### stery

Onoff Saturn tapered for 1-1/8 to 1-1/2 head tube, ACB sealed bearings, top 41x30.2x7x45x45, bottom 51.9x40x8x45x45

### przerzutka

Sram GX Eagle, Type 3 roller bearing clutch, cage lock, 1x12s, X-Actuation 1:1

### manetki

Sram Trigger NX Eagle, 12s, X-Actuation 1:1, single click

### klamki hamulca

Sram G2 R, tool-free reach adjust

### uchwyty

Race Face Aeffect ebike, 165mm

### kierownica

Onoff Sulfur 1.0 double butted 6061 alloy, rise: 20mm, width: 780mm, 9 backsweep, 5 upsweep, 31.8mm barbore Onoff Desert, 1lock-on, 135mm, sizes: S/M L/XL

### mostek

Onoff Sulfur FG 30mm 0, 6061 forged alloy, 31.8mm barbore

### szttyca

Onoff Pija dropper internal, diameter 31.6mm, S size: 387x125mm, M size: 425x150mm, L/XL size: 465x170mm

**siodełko**

SDG BEL-AIR 3.0, EVA foam, steel rails

**tylna piasta**

DT 370, Boost 12x148mm, 3 Pawl system, IS 6 bolts

**kaseta**

Sram PG-1210, 11-50T, 12s

**rafki**

DT Swiss H1900 Spline 29, 30mm internal width, sleeved aluminum, tubeless ready, 28 spokes

**zamówienie numer**

010.21241

**przedni hamulec**

Sram G2 R, 4-piston caliper, Centerline 200mm IS 6 bolts one-piece rotor, steel-backed organic pads

**tylna obudowa**

Maxxis Minion DHR II 29x2.6, tubeless ready, 3C MAXX TERRA, EXO+ Protection, 120TPI, folding bead

**korba**

Sram X-Sync 2 Eagle 34T, steel, narrow-wide, 104 BCD

**silnik + akumulator**

Bosch Performance Line CX Cruise (25Km/h) GEN4, computer Bosch Kiox, Bosch Powertube 625Wh

**piasta przednia**

DT 370, Boost 15x110mm, IS 6 bolts

**łańcuch**

Sram SX Eagle, 12s, Powerlock

**szprychy**

DT Hybrid SP, straightpull

**obudowa**

Maxxis Minion DHF 29x2.6, tubeless ready, 3C MAXX TERRA, EXO+ Protection, 120TPI, folding bead

**amortyzator**

Fox Float DPX2 LV EVOL Performance, 205x65mm. Settings: compression 3 positions lever, low-speed rebound, air preload. Trunnion top mount, 25x10mm bottom bushings

**tylny hamulec**

Sram G2 R, 4-piston caliper, Centerline 200mm IS 6 bolts one-piece rotor, steel-backed organic pads

**regulacja amortyzatora**

CEC001 compression, Medium rebound, 0.2 volume spacer

**mocowanie przerzutki**

Mondraker M068

**Geometria**

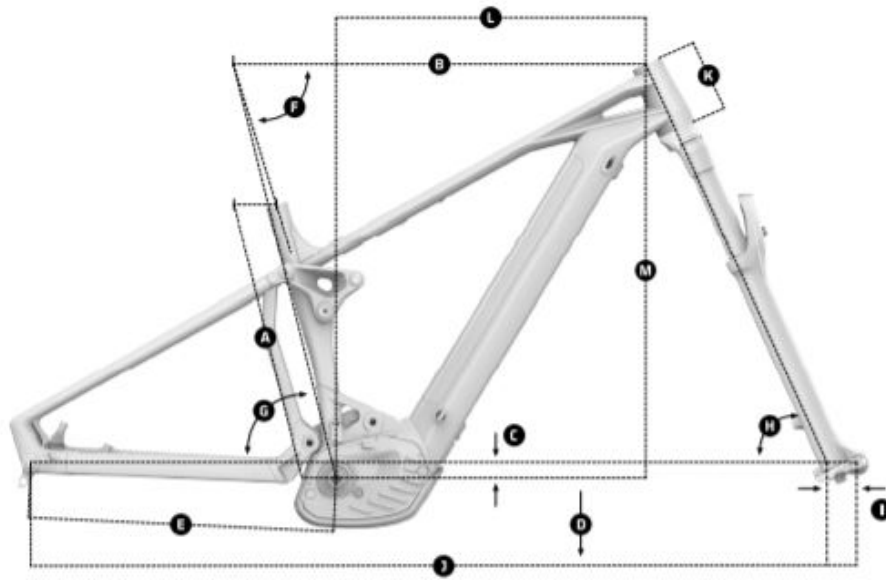

## GEOMETRY

Size	S	M	L	XL
<b>A</b> Seat Tube Length	380 mm	420 mm	450 mm	490 mm
<b>B</b> Top Tube Length	605 mm	625 mm	650 mm	670 mm
<b>C</b> Bottom Bracket Drop	-25 mm	-25 mm	-25 mm	-25 mm
<b>D</b> Bottom Bracket Height	350 mm	350 mm	350 mm	350 mm
<b>E</b> Chainstay Legth	455 mm	455 mm	455 mm	455 mm
<b>F</b> Seat Tube Angle, Actual	73.5°	73.5°	73.5°	73.5°
<b>G</b> Seat Tube Angle, Effective	76°	76°	76°	76°
<b>H</b> Head Tube Angle	65.5°	65.5°	65.5°	65.5°
<b>I</b> Fork Offset	44 mm	44 mm	44 mm	44 mm
<b>J</b> Wheelbase	1225 mm	1245 mm	1265 mm	1285 mm
<b>K</b> Head Tube Length	110 mm	110 mm	130 mm	130 mm
<b>L</b> Reach	450 mm	470 mm	490 mm	510 mm
<b>M</b> Stack	622 mm	622 mm	640 mm	640 mm