

CHASER, BLACK, 2021

obj. č: 010.21225



Sugerowana cena

23.299,00 zł

Aktualna cena

21.899,00 zł

Specyfikacje techniczne

produkowane rozmiary

S 380mm / M 420mm / L 450mm / XL 490mm

waga

24,8 Kg

rama

Chaser 6061 Alloy Stealth Evo, e-Bike Optimized Zero Suspension System, 150mm travel, Forward Geometry, internal removable battery, Boost 12x148mm rear axle, tapered head tube, one-piece Monoblock upper link, HHG internal cable routing, MAX capacity sealed bearings, oversize 17mm axles, integrated dropout speed sensor, exclusive plastic motor covers, shock mudguard

widelec

RockShox 35 Silver TK 29, 160mm, TurnKey, Solo Air, tapered steerer tube, Boost 15x110mm axle, 35mm steel stanchions, 44mm offset. Settings: compression adjustment at low-speed to lock, rebound, air preload

stery

Onoff Saturn tapered for 1-1/8 to 1-1/2 head tube, ACB sealed bearings, top 41x30.2x7x45x45, bottom 51.9x40x8x45x45

przerzutka

Sram SX Eagle, Type 3 roller bearing clutch, cage lock, long cage, 1x12s, X-actuation 1:1

manetki

Sram Trigger SX Eagle, 12s, X-Actuation 1:1, single click

klamki hamulca

Sram G2 R, tool-free reach adjust

uchwyty

Race Face Aeffect ebike, 165mm

kierownica

Onoff Sulfur 1.0 double butted 6061 alloy, rise: 20mm, width: 780mm, 9 backsweep, 5 upsweep, 31.8mm barbore Onoff Twin, 1lock-on, 135mm

mostek

Onoff Sulfur FG 30mm 0, 6061 forged alloy, 31.8mm barbore

sztyca

Onoff Pija dropper internal, diameter 31.6mm, S size: 387x125mm, M size: 425x150mm, L/XL size: 465x170mm

siodełko

Mondraker e-MTB custom design

piasta przednia

Formula DC711, Boost 15x110mm, sealed bearings, IS 6 bolts

tylna piasta

Formula EHL148 Boost 12x148mm, sealed bearings, IS 6 bolts

łańcuch

Sram SX Eagle, 12s, Powerlock

kaseta

Sram PG-1210, 11-50T, 12s

szprychy

CN round stainless steel

rafki

MDK-HP1 29, 30mm internal width, tubeless ready, 32 spokes

obudowa

Maxxis Rekon 29x2.6, tubeless ready, dual compound, EXO protection, 60TPI, folding bead

zamówienie numer

010.21225

amortyzator

RockShox Deluxe Select R Debonair, 205x65mm. Settings: Low-speed rebound, air preload. Trunnion top mount, 25x10mm bottom bushings

przedni hamulec

Sram G2 R, 4-piston caliper, Centerline 200mm IS 6 bolts one-piece rotor, steel-backed organic pads

tylny hamulec

Sram G2 R, 4-piston caliper, Centerline 200mm IS 6 bolts one-piece rotor, steel-backed organic pads

tylna obudowa

Maxxis Rekon 29x2.6, tubeless ready, dual compound, EXO protection, 60TPI, folding bead

regulacja amortyzatora

Light compression, Light rebound, 1 Token

korba

Sram X-Sync 2 Eagle 34T, steel, narrow-wide, 104 BCD

mocowanie przerzutki

Mondraker M068

silnik + akumulator

Bosch Performance Line CX Cruise (25Km/h) GEN4, computer Bosch Purion, Bosch Powertube 625Wh

Geometria

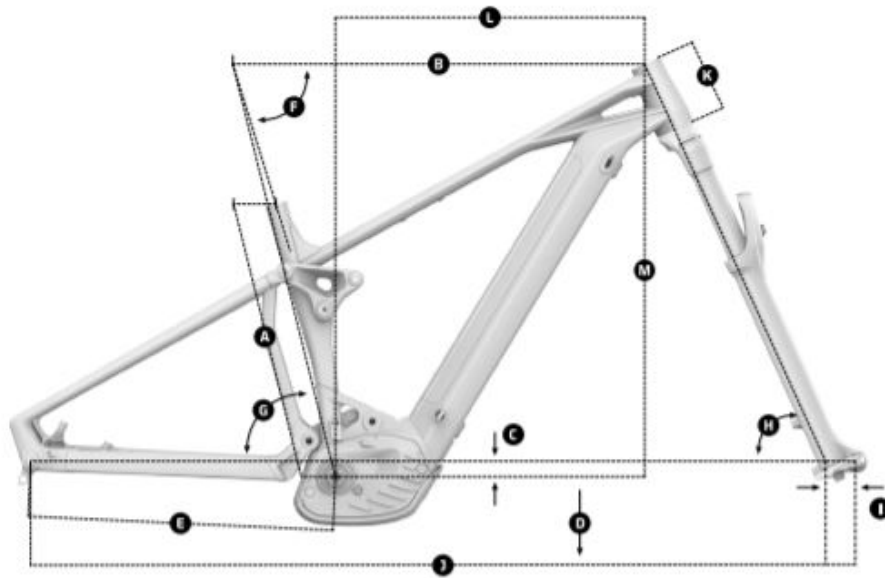

GEOMETRY

Size	S	M	L	XL
A Seat Tube Length	380 mm	420 mm	450 mm	490 mm
B Top Tube Length	605 mm	625 mm	650 mm	670 mm
C Bottom Bracket Drop	-25 mm	-25 mm	-25 mm	-25 mm
D Bottom Bracket Height	350 mm	350 mm	350 mm	350 mm
E Chainstay Legth	455 mm	455 mm	455 mm	455 mm
F Seat Tube Angle, Actual	73.5°	73.5°	73.5°	73.5°
G Seat Tube Angle, Effective	76°	76°	76°	76°
H Head Tube Angle	65.5°	65.5°	65.5°	65.5°
I Fork Offset	44 mm	44 mm	44 mm	44 mm
J Wheelbase	1225 mm	1245 mm	1265 mm	1285 mm
K Head Tube Length	110 mm	110 mm	130 mm	130 mm
L Reach	450 mm	470 mm	490 mm	510 mm
M Stack	622 mm	622 mm	640 mm	640 mm